



## User Guide

### GR10-2PHE HS Differential Pulse Positioning Module

19011286 A01

1

#### I. Overview

Thank you for purchasing the GR10-2PHE high speed differential pulse positioning module developed and manufactured independently by Inovance. This product delivers 2\*4 MHz high-speed differential outputs. It supports multiple pulse output modes, including direction+pulse or CW + CCW. It also supports homing positioning and left and right limiting. It is ideal choice for applications require a large number of axes.

This guide describes the specifications, characteristics and using methods of the product. Please read this guide carefully before using to ensure safe usage. Visit our website ([www.inovance.com](http://www.inovance.com)) for the latest version of the guide.

#### II. Safety Instructions

##### Safety Precautions

- Before installing, using, and maintaining this equipment, read the safety information and precautions thoroughly, and comply with them during operations.
- To ensure the safety of humans and equipment, follow the signs on the equipment and all the safety instructions in this user guide.
- The "CAUTION", "WARNING" and "DANGER" signs are only supplements to the safety instructions.
- Use this equipment according to the designated environment requirements. Damage caused by improper usage is not covered by warranty.
- Inovance shall take no responsibility for any personal injuries or property damage caused by improper usage.

##### Safety Levels and Definitions

- WARNING** : Indicates that failure to comply with the notice may result in severe personal injuries or even death.
- CAUTION** : The "CAUTION" sign indicates that failure to comply with the notice may result in minor or moderate personal injury or damage to the equipment.

Please keep this guide well so that it can be read when necessary and forward this guide to the end user.

##### During control system design

- WARNING**
  - Provide a safety circuit outside the PLC so that the control system can still work safely once external power failure or PLC fault occurs.
  - Add a fuse or circuit breaker because the module may smoke or catch fire due to long-time overcurrent caused by operation above rated current or load short-circuit.
- CAUTION**
  - An emergency stop circuit, a protection circuit, a forward/reverse operation interlocked circuit, and an upper position limit and lower position limit interlocked circuit must be set in the external circuits of PLC to prevent damage to the machine.
  - To ensure safe operation, for the output signals that may cause critical accidents, please design external protection circuit and safety mechanism;
  - Once PLC CPU detects abnormality in the system, all outputs may be closed; however, when a fault occurs in the controller circuit, the output may not be under control. Therefore, it is necessary to design an appropriate external control circuit to ensure normal operation;
  - If the PLC output units such as relays or transistors are damaged, the output may fail to switch between ON and OFF states according to the commands;
  - The PLC is designed to be used in indoor electrical environment (overvoltage category II). The power supply must have a system-level lightning protection device, assuring that overvoltage due to lightning shock cannot be applied to the PLC power supply input terminals, signal input terminals and output terminals and so forth, so as to avoid damage to the equipment.

2

#### Installation



- Installation must be carried out by the specialists who have received the necessary electrical training and understood enough electrical knowledge.
- Disconnect all external power supplies of the system before removing/installing the module. Failure to do so may result in electric shock, module fault or malfunction.
- Do not use the PLC where there are dust, oil smoke, conductive dust, corrosive or combustible gases, or exposed to high temperature, condensation, wind & rain, or subject to vibration and impact. Electric shock, fire and malfunction may also result in damage or deterioration to the product.
- The PLC is open-type equipment that must be installed in a control cabinet with lock (cabinet housing protection > IP20). Only the personnel who have received the necessary electrical training and understood enough electrical knowledge can open the cabinet.



- Prevent metal filings and wire ends from dropping into ventilation holes of the PLC during installation. Failure to comply may result in fire, fault and malfunction.
- Ensure there are no foreign matters on ventilation surface. Failure to comply may result in poor ventilation, which may cause fire, fault and malfunction.
- Ensure the module is connected to the respective connector securely and hook the module firmly. Improper installation may result in malfunction, fault or fall-off.

#### Wiring



- Wiring must be carried out by personnel who have received the necessary electrical training and understood enough electrical knowledge.
- Disconnect all external power supplies of the system before wiring. Failure to comply may result in electric shock, module fault or malfunction.
- Install the terminal cover attached to the product before power-on or operation after wiring is completed. Failure to comply may result in electric shock
- Perform good insulation on terminals so that insulation distance between cables will not reduce after cables are connected to terminals. Failure to comply may result in electric shock or damage to the equipment.



- Prevent dropping metal filings and wire ends drop into ventilation holes of the PLC at wiring. Failure to comply may result in fire, fault and malfunction.
- The external wiring specification and installation method must comply with local regulations. For details, see the wiring section in this guide.
- To ensure safety of equipment and operator, use cables with sufficient diameter and connect the cables to ground reliably.
- Ensure that all cables are connected to the correct interface. Failure to comply may result in module and external equipment fault.
- Tighten bolts on the terminal block in the specified torque range. If the terminal is not tight, short-circuit, fire or malfunction may be caused. If the terminal is too tight, fall-off, short-circuit, fire or malfunction may be caused.
- If the connector is used to connect with external equipment, perform correct crimping or welding with the tool specified by manufacturer. If connection is in poor contact, short-circuit, fire or malfunction may be caused.
- A label on the top of the module is to prevent foreign matters entering the module. Do not remove the label during wiring. Remember to remove it before system operation, facilitating ventilation.
- Do not bundle control wires, communication wires and power cables together. They must be run with distance of more than 100 mm. Otherwise, noise may result in malfunction.
- Select shielded cable for high-frequency signal input/output in applications with serious interference so as to enhance system anti-interference ability.

#### Operation and Maintenance



- Maintenance & inspection must be carried out by personnel who have the necessary electrical training and experience.
- Do not touch the terminals while the power is on. Failure to comply may result in electric shock or malfunction.
- Disconnect all external power supplies of the system before cleaning the module or re-tightening screws on the terminal block or screws of the connector. Failure to comply may result in electric shock.
- Disconnect all external power supplies of the system before removing the module or connecting/removing the communication wirings. Failure to comply may result in electric shock or malfunction.



- Get with the guide and ensure safety before online modification, forcible output, and RUN/STOP operation.
- Disconnect the power supply before installing/removing the extension card.

#### Disposal



- Treat scrapped module as industrial waste. Dispose the battery according to local laws and regulations.

3

### III. Product Information

#### Model Number and Nameplate

GR10 - 2PHE			
Mark	Description	Mark	Aux. Function
G	General Module	E	EtherCAT communication
R	Remote module		
Mark	Series	Mark	Module Type
10	10	PH	High-speed DIFF output pulse positioning
		Mark	Outputs
		2	2

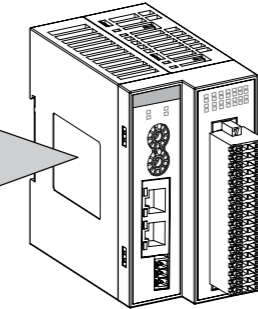
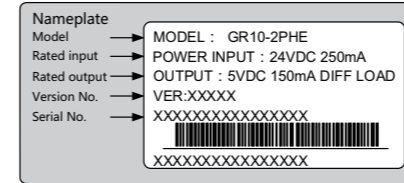
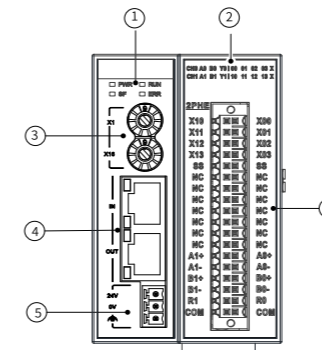

Figure 1 Description of model and nameplate

Model	Category	Description	Applicable Model
GR10-2PHE	EtherCAT high-speed differential pulse positioning module	Supports 2-channel high-speed differential output pulse and 8 inputs	AM600 series

#### External Interface



No.	Interface Name	Function			
①	State indicator	PWR	Power indicator	Green	ON when power supply is switched on
		RUN	Running status indicator	Green	ON when the module is in normal operation
		SF	Fault indicator	Red	ON when the module is faulty
		ERR	State machine error indicator	Red	ON when an error occurs in the state machine
②	Signal indicator	CH0/1	Indicator	Green	On when channel 0/1 is ready to output
		A/B	Pulse+direction Indicator	Green	/
		X0-X3	Digital input indicator	Green	On when the input signal is active
③	Address DIP switch	16-bit station address rotary switch. Decimal slave address = ADDR1*16+ADDR0 (address 0-255)			
④	EtherCAT communication port	X1 IN:	EtherCAT input		
		X2 OUT:	EtherCAT output for connecting back-end EtherCAT slaves		
⑤	24 V power input terminal	For module power supply input			
⑥	User output terminals	See "Electrical Design Reference" for details			

4

#### General Specifications

Item	Specifications
Power supply specifications	24 VDC (20.4 VDC to 28.8 VDC) (-15% to +20%)
Input current	Max. 0.25 A
Number of positioning channels	2
Ordinary output signal	Sink output: 24 V, response time: 0.5 ms
Differential pulse output	Pulse+direction, CW/CCW, A/B (output frequency: 4 MHz)
Digital input	8 (sink and source)
System program upgrade method	USB firmware upgrade
Positioning	Absolute pulse positioning, relative pulse positioning, speed control, multiple homing methods
Communication protocol	EtherCAT industrial real-time bus protocol, 100 Mbps
Network port/network cable	Standard network port with Cat 5e network cables below 100 meters
Station number range	1-255 if set by DIP switch 0-65535 if automatically allocated through a network bus.
Operating temperature	-5-55°C
Storage temperature	-25-70°C
Humidity	10-95%, no-condensation
IP rating	IP20

The specific performance indicators are as follows:

Item	Specifications
Communication protocol	EtherCAT protocol
Service supported	CoE (PDO, SDO)
Min. sync period	500 us (TYP)
Synchronization mode	Input and output synchronization or DC-distributed clock
Physical layer	100BASE-TX
Baud rate	100 Mbit/s (100Base-TX)
Duplex mode	Full duplex
Topological structure	Linear topological structure
Transmission medium	Network cables, see "Electrical Design Reference"
Transmission distance	Less than 100 m between two nodes
EtherCAT frame length	44-1,498 bytes
Process data	Max. 1486 bytes per frame
Synchronization jitter of two slave stations	< 1us
Update time	Approx. 500 us

#### Output specification

Item	SINK output	Item	Differential output
Output type	Transistor NPN	Output type	5 V differential output
ON response time	Less than 0.5 ms	Insulation	Optocoupler isolation
Insulation	Optocoupler isolation	Max. output frequency	4 MHz
Open-circuit leakage current	Less than 0.1 mA/30 VDC	Output mode	Pulse+direction, A/B phase single frequency, CW/CCW
Min. load	5 mA (DC5V-24V)	Number of channels	2
Max. load	Resistive load: 0.5 A/point		
	Inductive load: 7.2 W/24 V Lamp load: 0.9 W/24 V	--	--

#### Input specification

Item	Specifications
Input type	SINK/SOURCE input
Input voltage	DC 24 V
Input resistance	3.3KΩ
Input is ON	Input current is above 3.5 mA
Input is OFF	Input current is below 1.5 mA

### IV. Mechanical Design Reference

#### Mounting Dimensions

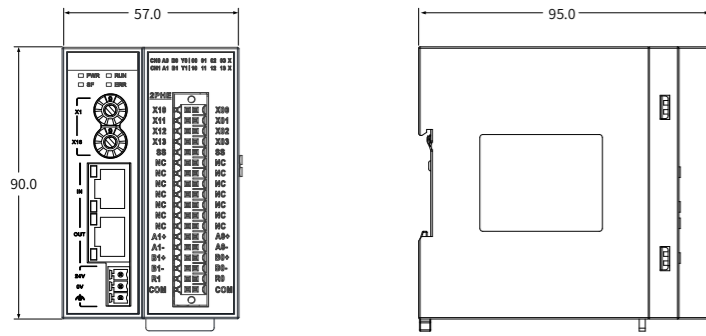

### V. Electrical Design Reference

#### Cable Preparation

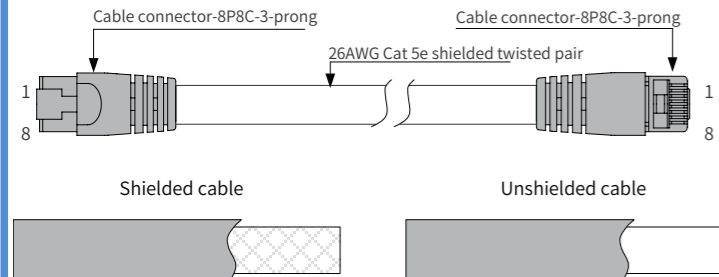

Use Cat 5e shielded twisted pair (STP) cables, with injection molded and iron shelled connector.

#### Signal pins

Pin	Signal	Signal Direction	Signal Description
1	TD+	Output	Data transmission+
2	TD-	Output	Data transmission-
3	RD+	Input	Data reception+
4	--	--	Not used
5	--	--	Not used
6	RD-	Input	Data reception-
7	--	--	Not used
8	--	--	Not used

#### Length requirements:

According to FastEthernet technology, when an EtherCAT bus is used, the length of the cable between the devices must not exceed 100 meters. Exceeding this length will attenuate the signal and affect communication.

#### Technical requirements:

100% continuity test, no short circuit, open circuit, misalignment and poor contact. Use a shielded cable as the EtherCAT bus for network data transmission, with the following recommended specifications:

Item	Specifications
Cable type	Flexible crossover cable, S-FTP, Cat 5e
Complied standards:	EIA/TIA568A, EN50173, ISO/IEC11801 EIA/TI Abulletin TSB, EIA/TIA SB40-A&TSB36
Conductor cross section	AWG26
Conductor type	Twisted pair
Pair	4

#### Communication Wiring

1) EtherCAT connection

Insert the cable into the EtherCAT port of the communication module until you hear a click sound.

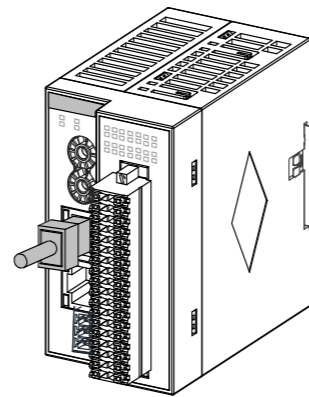
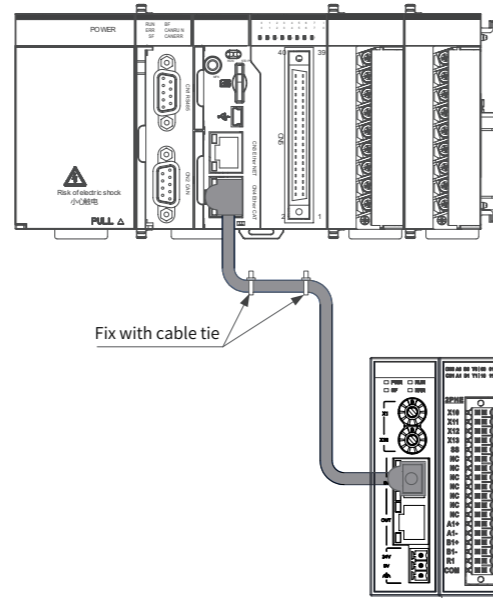

Figure 2 Cable connection diagram

2) Requirements for securing communication cable

To protect the communication cable from any tension and to ensure communication stability, fix the cable end which is near the device before EtherCAT communication, as shown below:



3) Fault Indication and troubleshooting for EtherCAT remote communication expansion module

EtherCAT slave station:

LED indicator	Indication	Solution
RUN	OFF	No connection between EtherCAT master and slave Check configuration and parameter assignment; Check the communication address Check that the length and other specifications of the network cable are as specified.
RUN	Blinking	EtherCAT slave is in a state other than OP Check slave configuration for any missing, faulty or unconfigured module.
ERR	Blinking	No data exchange between EtherCAT master and slave Check that the cable connector is inserted correctly; Check that the network cable is intact; Re-power on.
SF	Steady ON	Output channel is faulty For details, see the application manual of the module.

#### Cable Selection

Material Name	Model	Applicable Cable		Manufacturer Name	Crimping Tool
		Diameter Chinese Standard/MM	AWG		
Tubular lug	GTVE07512	0.75	21	Suzhou Yuanli	YAC-5

#### Cable preparing procedures:

Remove the insulation of the cable so that a length of 11–14 mm of the conductor is exposed, and put the cable through a cable marking sleeve. Insert the exposed end into the hole of the cable lug, and then crimp it with recommended crimping tool.

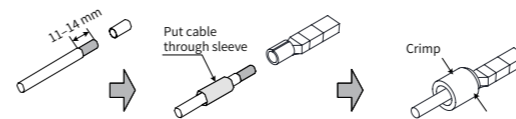
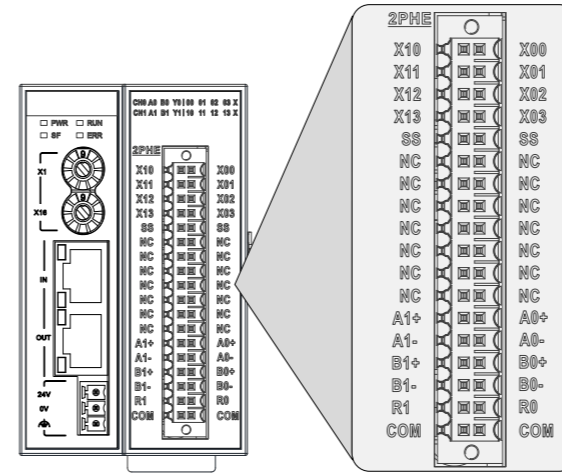
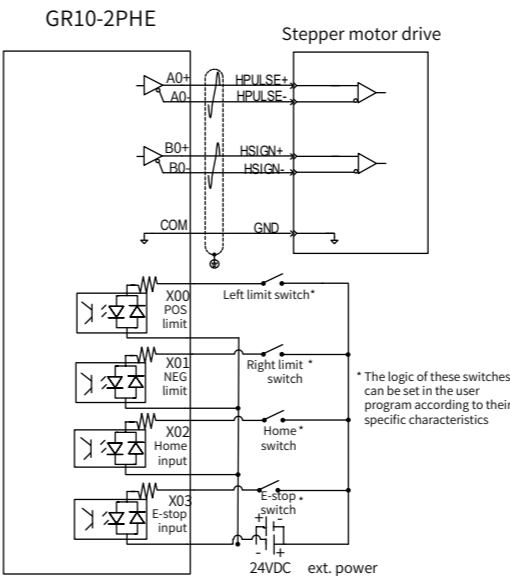

Figure 3 Cable preparation

#### Terminal Layout



#### User output terminal wiring



#### GR10-2PHE Servo motor drive

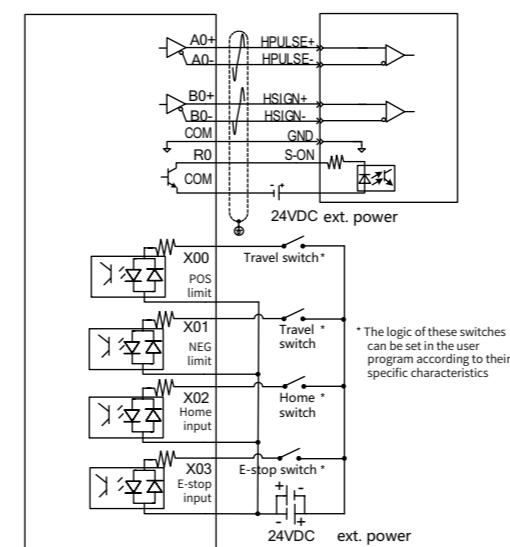

Figure 4 Output terminal wiring

\* The common GND of the module must be connected to the GND terminal of the drive to reduce noise interference.

#### External Wiring

Ext. Wiring	Signal Name Column B	Terminal No.	Signal Name Column A	Ext. Wiring
	Input ( X10 )	36	35	Input ( X00 )
	Input ( X11 )	34	33	Input ( X01 )
	Input ( X12 )	3	31	Input ( X02 )
	Input ( X13 )	30	29	Input ( X03 )
	SS COM ( SS )	28	27	SS COM ( SS )
	Not connected ( NC )	26	25	Not connected ( NC )
	Not connected ( NC )	24	23	Not connected ( NC )
	Not connected ( NC )	22	21	Not connected ( NC )
	Not connected ( NC )	20	19	Not connected ( NC )
	Not connected ( NC )	18	17	Not connected ( NC )
	Not connected ( NC )	16	15	Not connected ( NC )
	Not connected ( NC )	14	13	Not connected ( NC )
	Pulse output ( A1+ )	12	11	Pulse output ( A0+ )
	Pulse output ( A1- )	10	9	Pulse output ( A0- )
	Pulse output ( B1+ )	8	7	Pulse output ( B0+ )
	Pulse output ( B1- )	6	5	Pulse output ( B0- )
	Enable output ( R1 )	4	3	Enable output ( R0 )
	Common GND ( COM )	2	1	Common GND ( COM )

Figure 5 Module wiring diagram

\*1 4-core shielded twisted pair cables are used for differential output to reduce noise interference;

\*2 The common GND for differential output must be connected to the GND terminal of the servo drive to reduce noise interference.

\*3 Ensure that the metal spring piece at the bottom the of the module is securely installed. Mount the module on a well-grounded metal bracket, and ensure that the spring piece is in good contact with the bracket.

#### Wiring Precautions

Do not bundle the cable together with AC cable, main lines, high voltage cable and so forth, otherwise it may result in an increased noise, surge and induction.

Apply single-point grounding for the shielding of shielded cable and solder sealed cable.

Tubed and solderless crimp terminal cannot be used with terminal block. Using marking sleeve or insulation sleeve to cover the cable connector part of the crimp terminals is recommended.

## INOVANCE Warranty Agreement

The warranty period of the product is 18 months (subject to information indicated by the barcode on the product). During the warranty period, if the product fails or is damaged under the condition of normal use by following the instructions, Inovance will be responsible for free maintenance.

Within the warranty period, maintenance will be charged for the damages due to the following causes:

- 1) Improper use or uninstallation/repair/modification without prior permission
- 2) Fire, flood, abnormal voltage, other disasters, and secondary disasters
- 3) Hardware damage caused by dropping or transportation after procurement
- 4) Failure to operate the product by observing the User Guide provided by Inovance
- 5) Faults and damages caused by factors outside of the product (such as peripheral devices)

The maintenance fee is charged according to the latest Maintenance Price List of Inovance.

The Product Warranty Card is not re-issued. Keep the card and present it to the maintenance personnel when seeking maintenance.

If there is any problem during the service, contact us or our agent directly.

You are assumed to agree on terms and conditions of this warranty agreement by purchase of the product. This agreement shall be interpreted by Suzhou Inovance Technology Co., Ltd.

Suzhou Inovance Technology Co., Ltd.

Address: No.16 Youxiang Road, Yuexi, Wuzhong District, Suzhou 215104

Service hotline: 4000-300124

Website: <http://www.inovance.com>